

# Mouldings

**J19**  
0.089 kg/ft  
0.29 kg/m

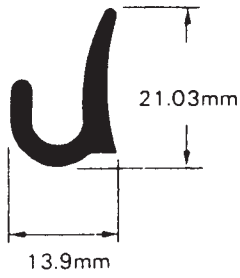

**J4**  
0.050 kg/ft  
0.17 kg/m

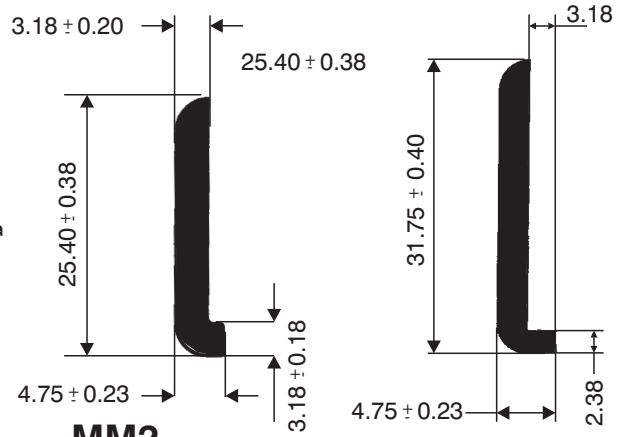
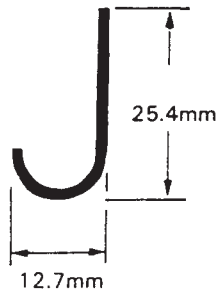

**MM2**

**MM23**

**J5**  
0.063 kg/ft  
0.21 kg/m

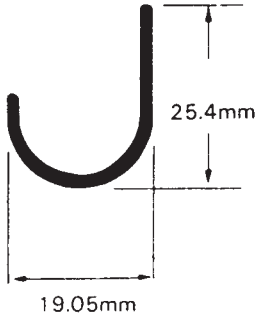

**J6**  
0.091 kg/ft  
0.30 kg/m

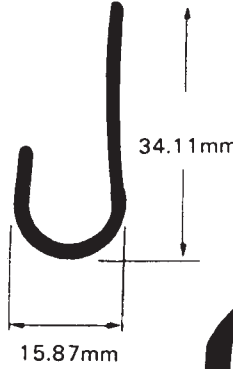

**MM62**  
.269 kg/m  
HE9TB  
5 mtr lengths

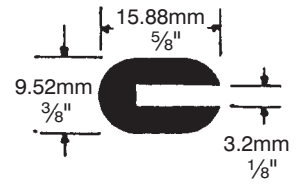

**CC1**  
0.066 kg/ft  
0.22 kg/m

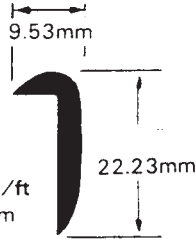

**J10**  
0.131 kg/ft  
0.43 kg/m

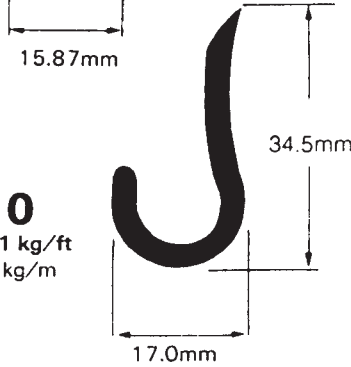

**CC5**  
0.110 kg/ft  
0.36 kg/m

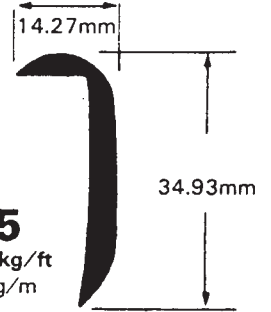

**CC2**  
0.069 kg/ft  
0.23 kg/m

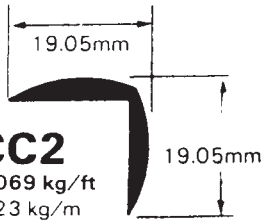

**CC4**  
0.090 kg/ft  
0.30 kg/m

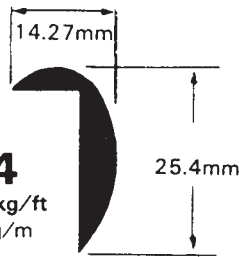

**CC9**  
0.067 kg/ft  
0.22 kg/m

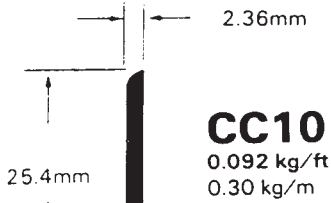
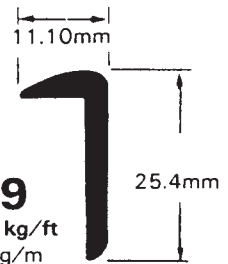

**CC10**  
0.092 kg/ft  
0.30 kg/m

**EC1**  
0.09 kg/ft  
0.30 kg/m

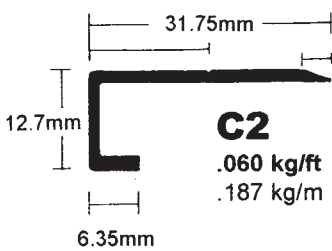
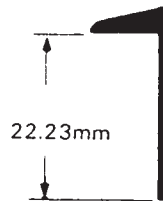

**C2**  
.060 kg/ft  
.187 kg/m

**RC1**  
0.080 kg/ft  
0.263 kg/m

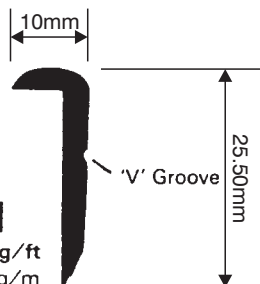

**J9**  
0.12 kg/ft  
0.394 kg/m

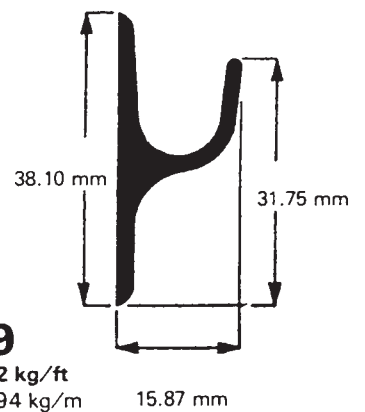

# Mouldings

## HALF ROUNDS

	ins	mm	Weight kg/ft	Size kg/m
<b>HR4</b>	0.75 x .187	19.05 x 4.75	.043	.14
<b>HR6</b>	1.00 x .187	25.40 x 4.75	.060	.20
<b>HR9</b>	1.50 x .25	38.10 x 6.35	.113	.37
<b>HR10</b>	2.00 x .25	50.80 x 6.35	.148	.49

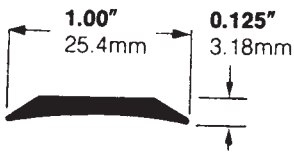

**DB1**  
0.049 kg/ft  
0.16 kg/m

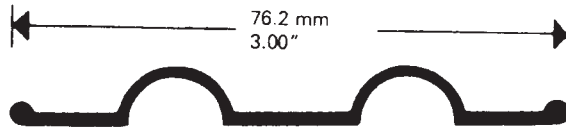

**PP2 INTERIOR RUB RAIL**  
0.132 kg/ft  
0.433 kg/m

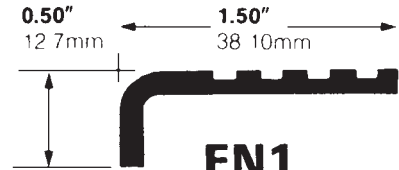

**FN1**  
0.112 kg/ft  
0.37 kg/m

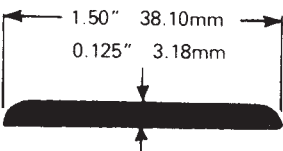

**DR3**  
0.101 kg/ft  
0.33 kg/m

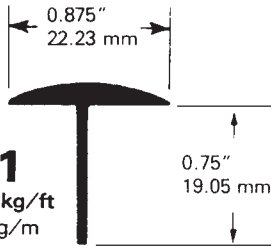

**DL1**  
0.065 kg/ft  
0.21 kg/m  
**DOOR LAP TEE**

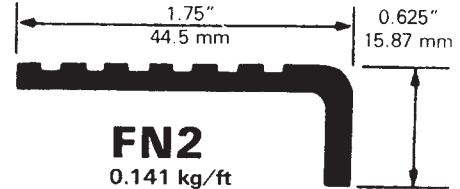

**FN2**  
0.141 kg/ft  
0.46 kg/m

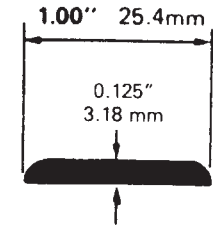

**DR1**  
0.064 kg/ft  
0.21 kg/m  
also DR2 (6082 TF)

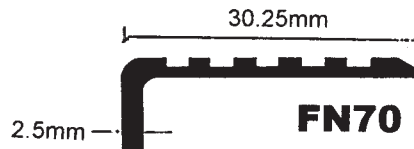

**FN70**  
0.079 kg/ft  
0.26 kg/m

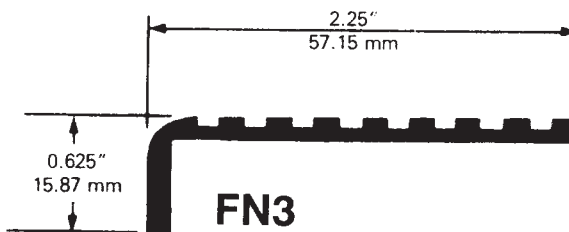

**FN3**  
0.152 kg/ft  
0.50 kg/m

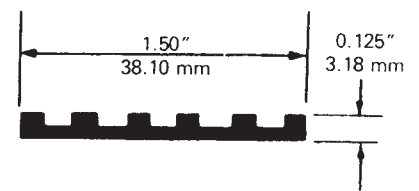

**FS4**  
0.075 kg/ft  
0.25 kg/m

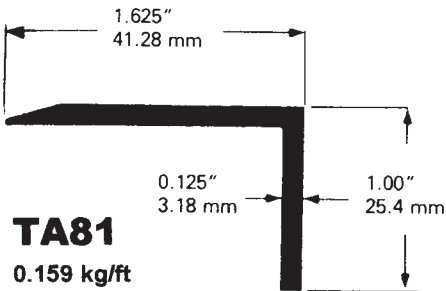

**TA81**  
0.159 kg/ft  
0.52 kg/m  
**FLOOR CAPPING**

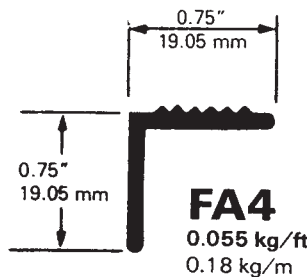

**FA4**  
0.055 kg/ft  
0.18 kg/m

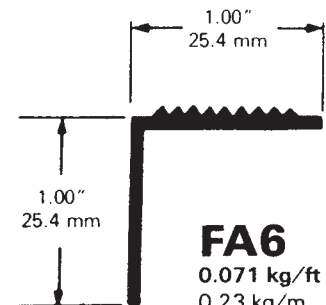

**FA6**  
0.071 kg/ft  
0.23 kg/m

# Mouldings & Miscellaneous Items



**CCAC2**  
RUBBER SECTION

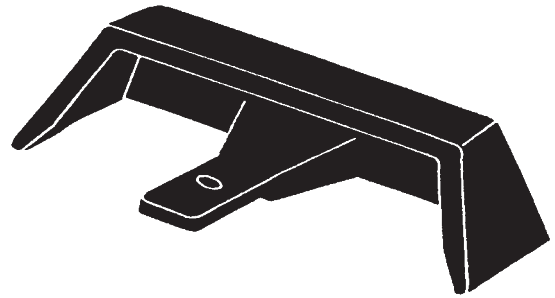

**CS60A**  
END CAP *available in alloy*



**CCAC1**  
ALUMINIUM CARRIER

**CS60P**  
END CAP *available in plastic*

## Hose Tray Extrusion

